

# AMBIENT REALITY EFFECTS

## DIY QUICK GUIDE

1. Connecting Custom Devices
2. Adding Loads in Series
3. Mixed Voltage Loads
4. High Current Loads – Transistor
5. High Current Loads – MOSFET

# AMBIENT REALITY EFFECTS

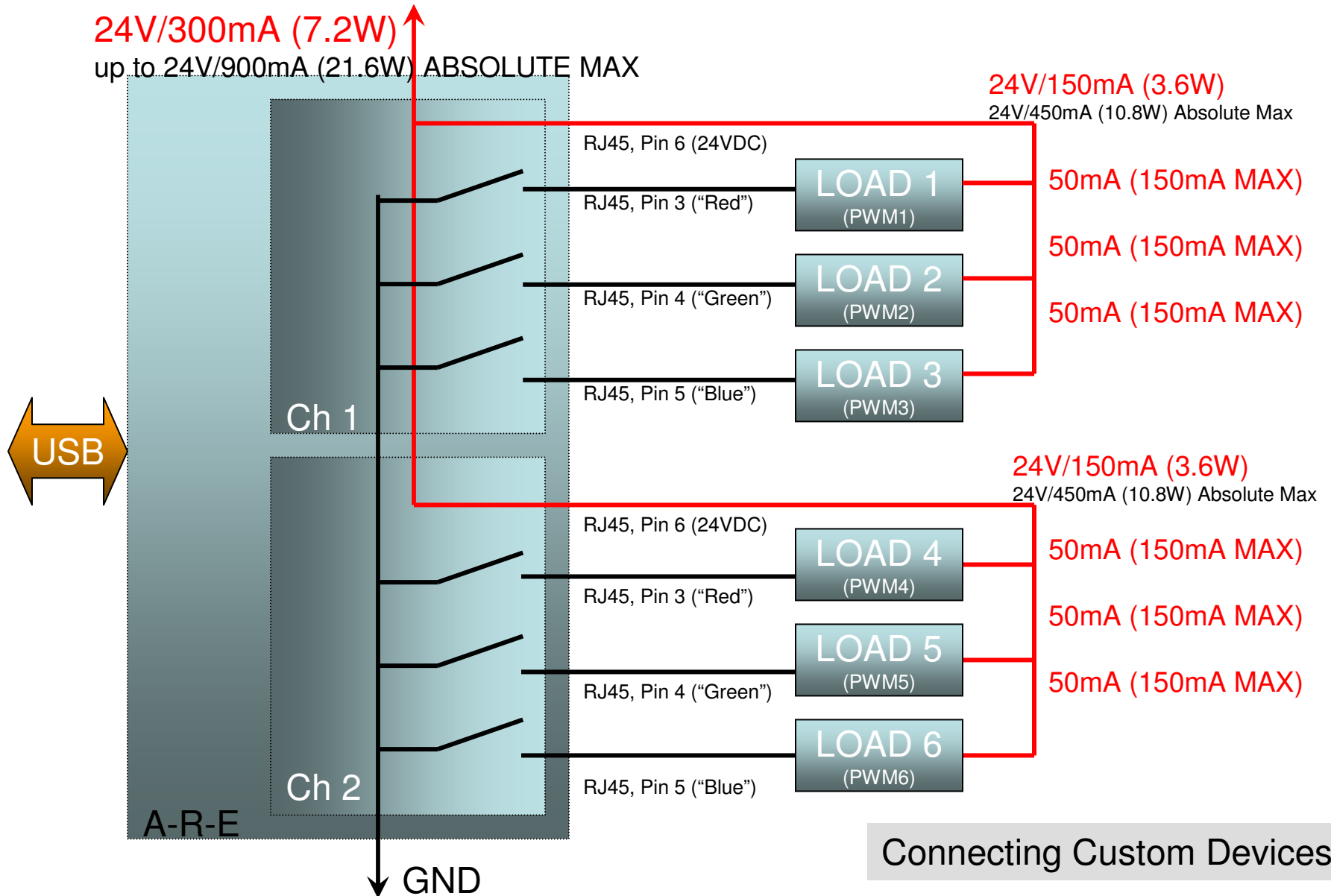

# AMBIENT REALITY EFFECTS

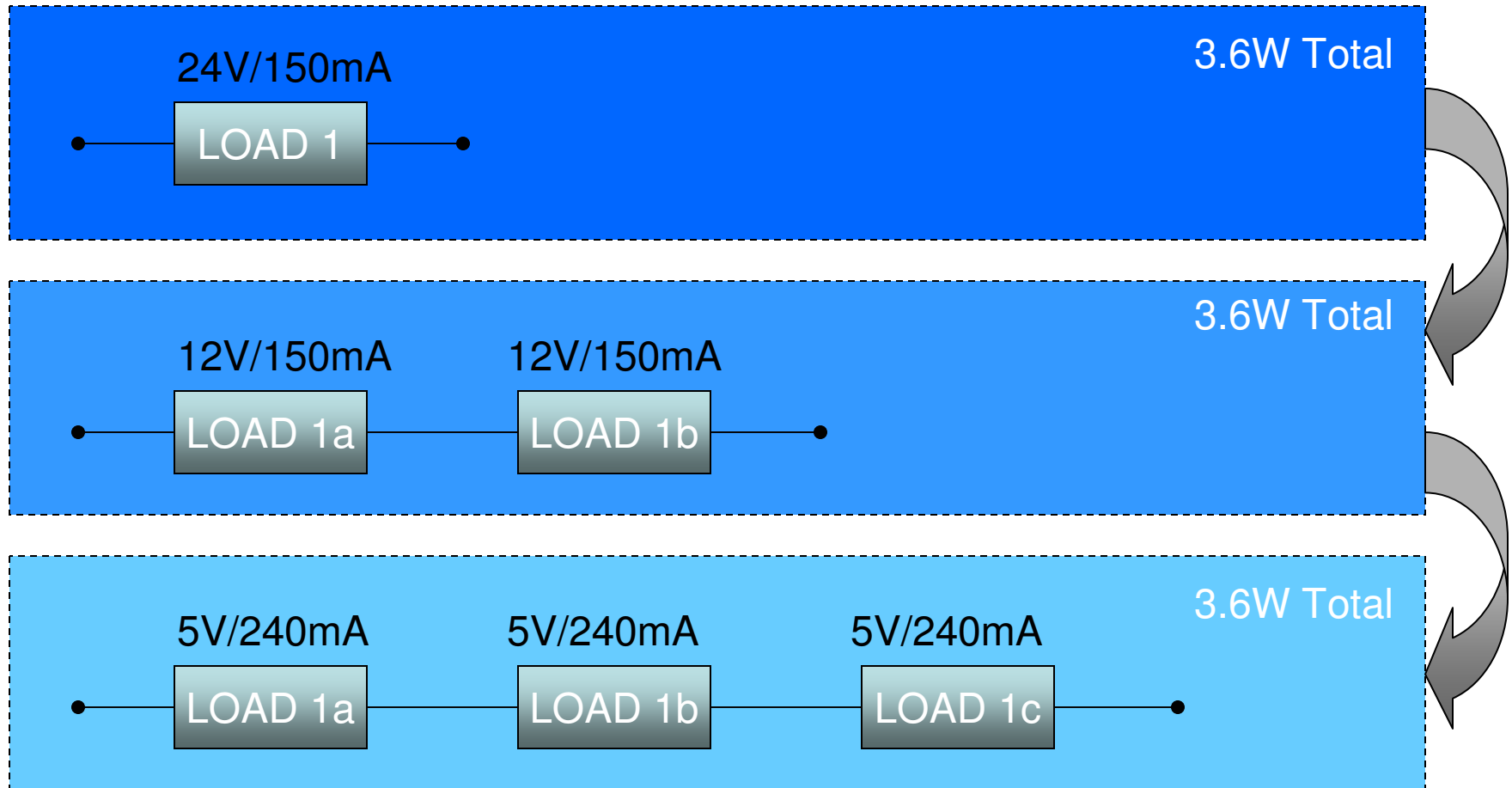

Adding Loads in Series

# AMBIENT REALITY EFFECTS

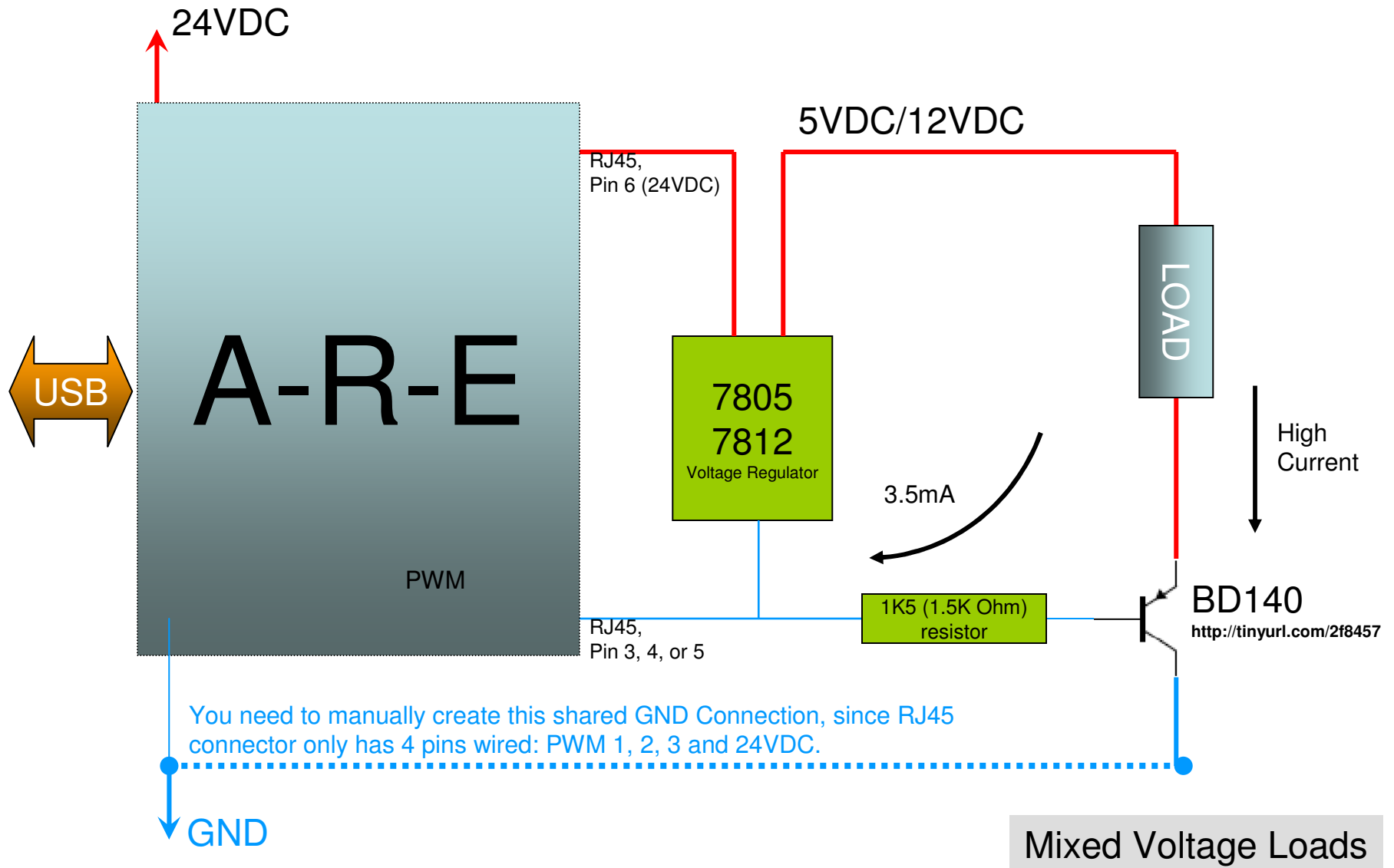

# AMBIENT REALITY EFFECTS

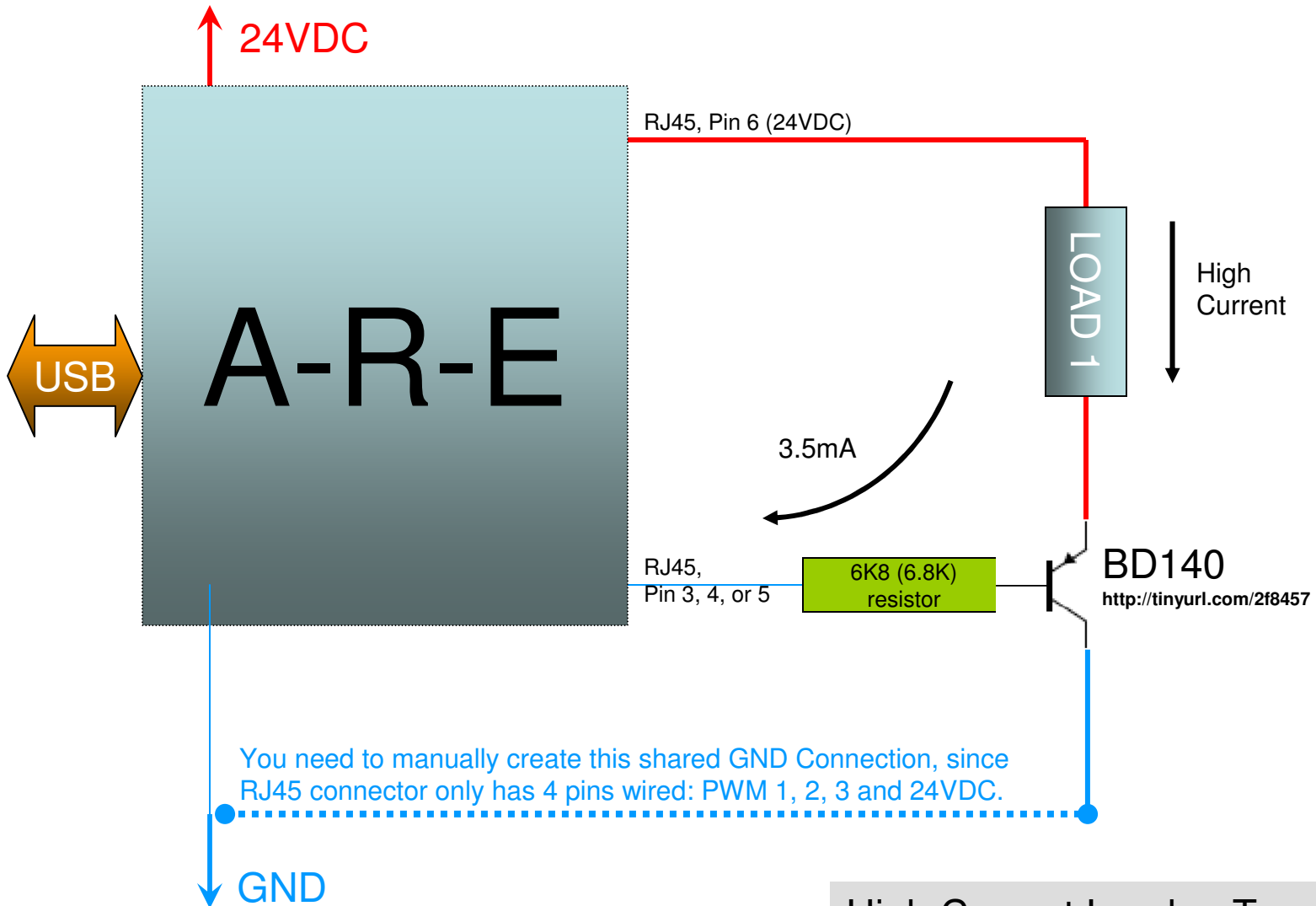

High Current Loads - Transistor

# AMBIENT REALITY EFFECTS

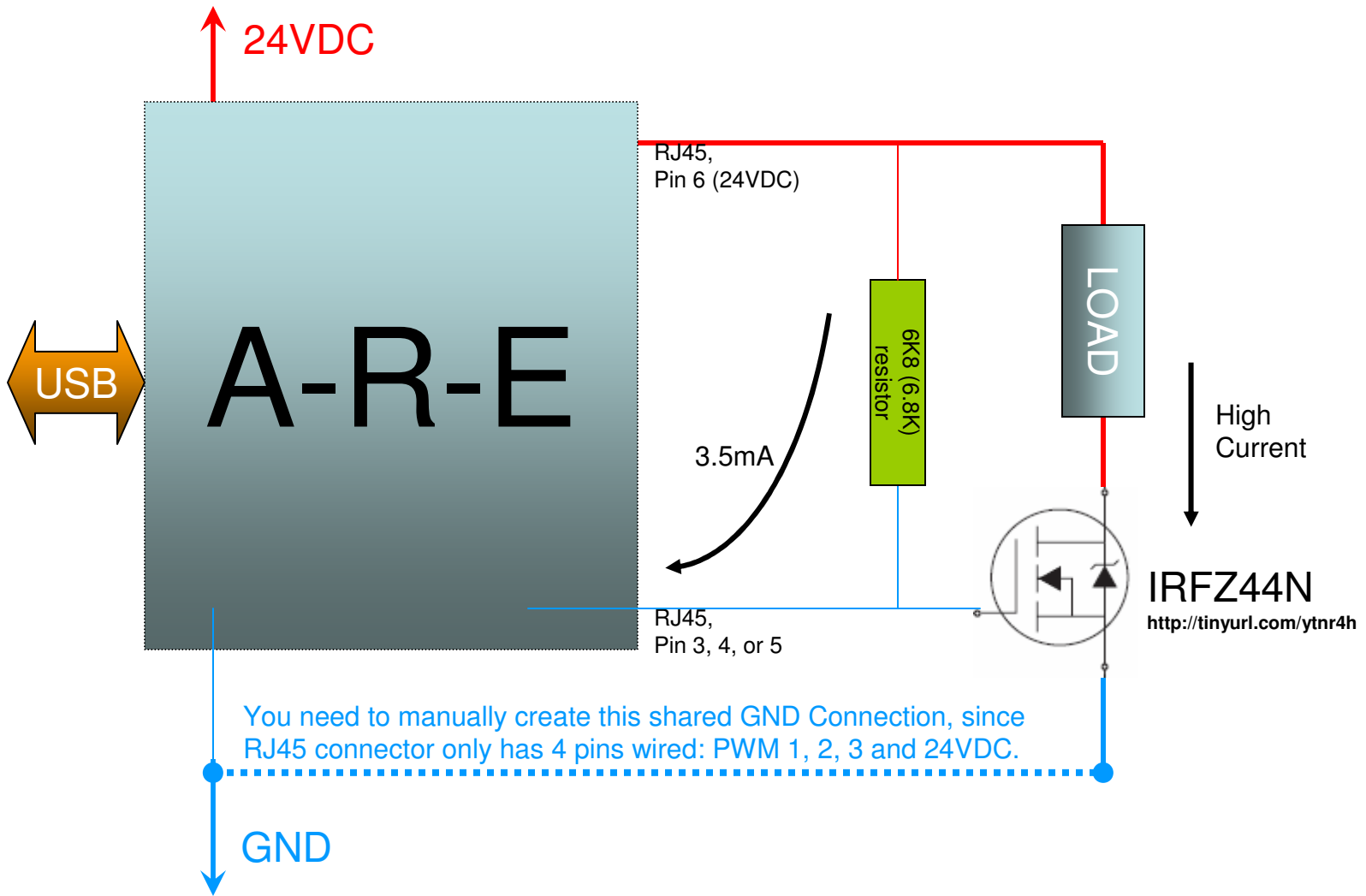

High Current Loads - MOSFET